

FAST HIGH-POWER POWER SUPPLY FOR SCANNING MAGNETS OF CNAO MEDICAL ACCELERATOR

M. Incurvati[#], F. Burini, M. Farioli, G. Taddia, OCEM SpA, San Giorgio di Piano (BO), Italy
M. Donetti, S. Toncelli, CNAO Foundation, Milan, Italy
G. Venchi, University of Pavia Electrical Engineering, Pavia, Italy
I. De Cesaris, C. Sanelli, F. Voelker, INFN Laboratori Nazionali di Frascati, Frascati (RM), Italy
S. Giordanengo, F. Marchetto, INFN Sezione di Torino, Torino, Italy

Abstract

The paper presents the design aspects and performance measurements of the CNAO Scanning Magnets' power supply (PS) rated $\pm 550\text{A}/\pm 660\text{V}$ and developed in collaboration between OCEM SpA and INFN-CNAO. CNAO is a medical synchrotron producing carbon ions and protons for the cure of deep tumours. The Scanning Magnets are dipole magnets used to move the beam in an x-y plane at the very end of the beam extraction line. The PS current will be set in order to cover the targeted tumour area. To accomplish such a task the specifications of the PS are very stringent: current ramp speed is required to be as fast as 100 kA/s with an overall precision class of 100 ppm. Moreover the wide (20x20 cm²) area to be covered by the beam requires a wide current range. High voltage peaks are required during transients whereas low voltage is needed during steady state. The above characteristics are challenging design issues both with respect to topology and control optimization.

INTRODUCTION

The CNAO medical synchrotron is finishing the installation and has just started the sources and LEBT commissioning and the PSs for the scanning magnets [1] complete the long list of topologies built in the past years by OCEM [2-3]. They will be used to feed dipole magnets to move the beam as a paintbrush on the targeted tumour area. The treatment plan is controlled by the Beam Delivery System (BDS) group optimizing the movements of the beam as a function of tumour shape. The BDS drives the PSs current through a 4 Mbaud optical link, sending a new current setting every 25 μs to precisely adjusting the beam position. The PSs send back to the BDS some useful information (actual current, set current, errors,...) This communication system allows for fast current control and safe operation. One of the main issues the treatment plan addresses is the maximization of the delivered dose in ill zones while minimizing it in healthful areas. To accomplish such tasks high precision and fast transient behaviour are required. The PSs also communicate with a Central Control System (CS) and a Timing System (TS) through Ethernet interfaces. The CS can thus collect information on the actual state of the PS and the TS synchronizes it with the main synchrotron

events (injection, acceleration, extraction, energy,...)

POWER SUPPLY CHARACTERISTICS

The PS principle diagram and a picture of it are shown in Fig.1 while its main characteristics and requirements are listed in Tab.1. The PS is composed of three main modules: a Booster (BO), and two Active Filters (AFs). The BO is a high-voltage high current IGBT H-Bridge whereas the AFs are IGBT H-Bridges used in interleaved modulation.

The BO, which is in series with the filtered output of the AFs stage, provides high voltage when the larger current steps are commanded by the BDS. The AFs provide both for maximum output voltage during transients and fast regulation for steady state current.

Table 1: Power Supply Specifications

Electrical Characteristics		
$R_{\text{load}}=R_{\text{cable}}+R_{\text{magnet}}$	40 m Ω	Load Resistance
L_{load}	4.4 mH	Load Inductance
$I_{\text{load,nom}}$	± 540 A	Nominal Current
$V_{\text{load,max}}$	± 660 V	Output Voltage
Dynamical Characteristics		
$T_{\text{step}}+T_{\text{transient}}$	200 μs	Time to precision band
ΔI_{step}	<15 A	Current step amplitude
T_{between}	300 μs	Min time between steps
Slope	>100 kA/s	Current slope for ΔI_{step} and $T_{\text{step}}+T_{\text{transient}}$
Precision Requirements		
CSCR	0 to $\pm 100\%$ f.s.	Current setting control range
CSRR	60 ppm	Current setting and readout resolution
CP	± 100 ppm	Current precision after transient
CS8H	± 200 ppm	Current stability over 8 hour
CRPP	<100 ppm	Residual peak-to-peak current ripple
COUS	<100 ppm	Current over/under shoot during transient

[#]maurizio.incurvati@ocem.com

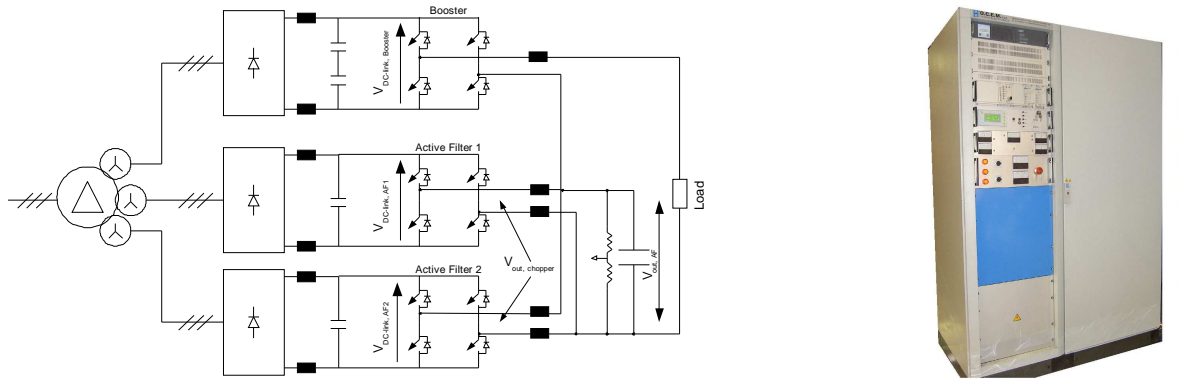

Figure 1: Scanning Magnets' Power Supply principle diagram and a picture

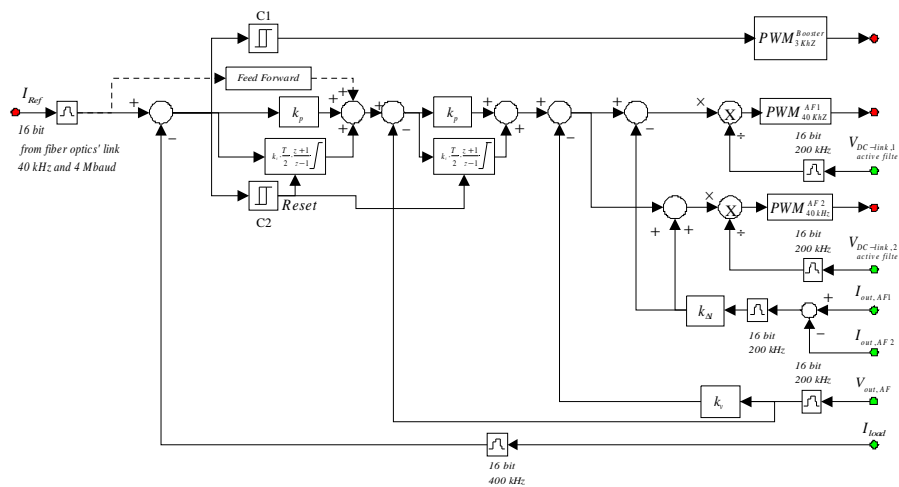

Figure 2: Control loops of the PS

Each leg of the AFs is switched at 20 kHz reaching at the output, with interleaving, an overall switching frequency of 80 kHz. Output filter design plays an important role in the overall performance of the PS.

CONTROL STRATEGY

As can be seen in Tab.1 the PS requirements are very stringent as the combination of dynamics and precision concern. After an in-depth analysis of the required performances and load characteristics, the following general principles were adopted:

- For current steps up to 2.5 A only the AFs are used while the BO is short circuited;
- For current steps larger than 2.5 A the BO is switched-on increasing ramp speed. The BO is switched-off by a comparator set at $I_{set} \pm 0.6$ A. The current is then driven to the set level by the control loops of the AFs.

The detailed control loops' diagram is shown in Fig.2. The main issues faced during the design and tuning phases where:

- Selection of suitable ADCs precision and sample frequency to track current variation as fast as 100 kA/s; the sample frequency is important to minimize the BO comparator uncertainty.

- Tuning of the current loop integrator optimizing anti wind-up and reset thresholds to avoid overshoots as much as possible;
- Tuning of the inner voltage loop parameters to linearize the chopper behaviour on the full range even at very low duty-cycles;
- Tuning of the BO comparator thresholds to take into account the delays of the drivers and IGBTs as well as their variation with current level;
- Evaluation of actual magnet load non ideality under fast current transients.

The additional loops contribute to the overall performances of the PS (current sharing of AFs bridges and DC-link voltage variation).

The control algorithm has been implemented on a National Instruments PXI system that allows both for fault and status monitoring and communication facilities under Real Time environment and FPGA programming for fast and flexible regulation. The FPGA board NI-7833R is equipped with 8+8 16 bit ADCs/DACs and several digital outputs. The ADCs have a sample frequency of 200 kS/s. Two phase shifted ADCs are used for the current acquisition to reach 400 kS/s. The control loops run on the FPGA at 2.5 μ s while the PWM has a quantization of 25 ns. To drive the 12 IGBTs a custom electronics has been developed by OCEM that fully

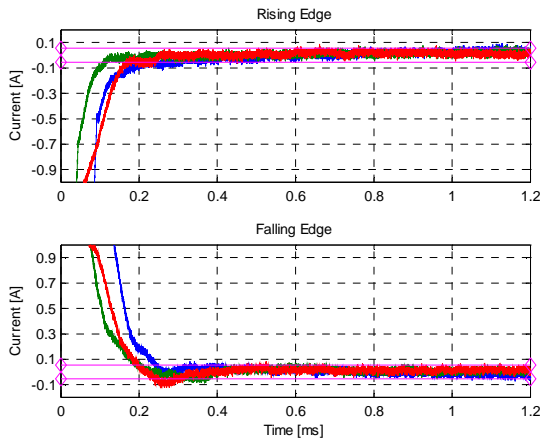

Figure 3: Current steps (0-15A,0-7A,0-2A)

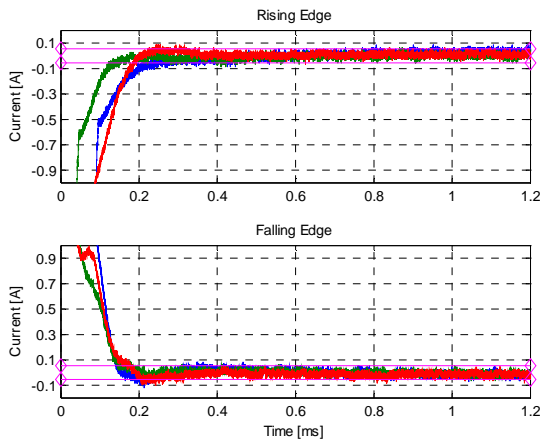

Figure 4: Current steps (525-540A,533-540A,538-540A)

integrates with PXI Bus generating optical signals directly from FPGA outputs.

EXPERIMENTAL RESULTS

A set of experimental results is presented. Figs. 3 and 4 show the typical current waveforms at the end of several steps. The figures' legend is as follows:

- Blue line: current step amplitude 15 A.
- Green line: current step amplitude 7 A.
- Red line: current step amplitude 2 A.

Each figure shows the rising and falling edge of the required step and the reached current level is represented by the zero on the vertical axis. Fig.3 shows the behaviour around 0 A dc level while Fig.4 is around the 540 A dc level. The start time of the current step is the origin of the horizontal axis; the steady state precision band of ± 55 mA is shown by purple lines and the time to enter in precision band is 200 μ s as from Tab.1. The 7 A and 15 A current steps include the BO+AF operation whereas the 2 A includes only the AF.

As can be seen the PS behaviour is quite homogeneous with respect to step amplitude and dc current level. Moreover the stringent transient time and steady state precision is met without any appreciable overshoot. The PS has shown uniform behaviour on the whole current

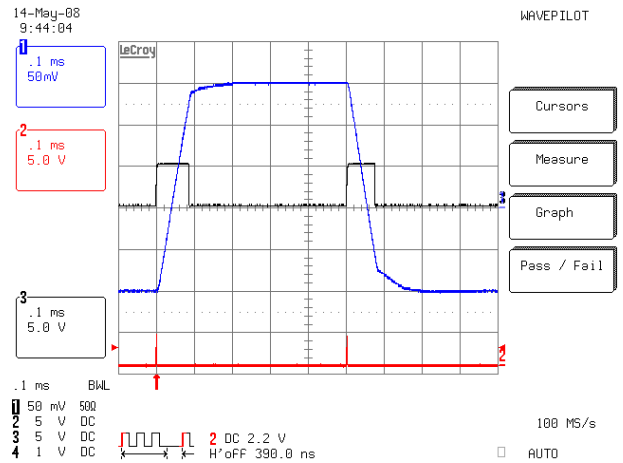

Figure 5: Typical current waveform

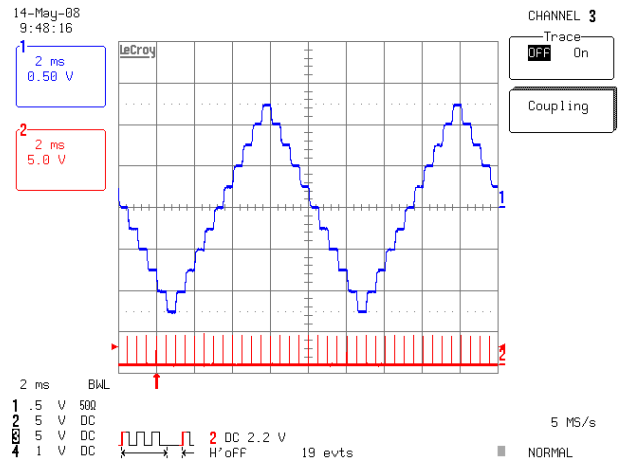

Figure 6: Example of current waveform for raster scanning

range even around the zero current level that represents the central position of the beam.

Fig.5 shows a typical current shape (blue line) of the PS for a 15 A step. It is clearly visible the current slope change as the BO switches-off and the smooth connection of the AF. Start trigger pulses are shown in red and BO on-off state is shown in black. A typical raster scanning current shape is shown in Fig. 6 where each step is of 15 A with 500 μ s between pulses; the number of steps is 10 and the current varies between -75 A and $+75$ A.

REFERENCES

- [1] C. Sanelli, F. Voelker, et Alt., "Specification of Power Supplies for eight scanning dipole magnets of the CNAO project", CNAO internal Spec. CNA-SPDF-007WXX-03018
- [2] M. Incurvati, C. Sanelli, G. Taddia, et Alt., "The Italian Hadrontherapy centre (CNAO): a review of the power supplies system for conventional magnets", EPAC06, Edinburgh.
- [3] M. Farioli, M. Incurvati, C. Sanelli, et Alt., "CNAO Resonance Sextupole Magnet Power Converter", EPAC06 Edinburgh.